

NOTES:  
 1. APPROX 2500 FT. USE FOUR-CONDUCTOR, #6 SOJ CABLE.  
 2. ALL OTHER FEEDERS AND BRANCH CIRCUITS SIZED PER NEC.  
 ST = SHUNT TRIP (120VAC)

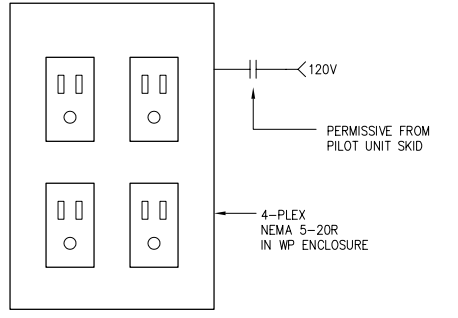

**SINGLE LINE DIAGRAM**  
 SCALE: NONE

**CHEMICAL FEED RECEPTACLE**  
 SCALE: NONE

LEGEND:  
 - CONTROLLER

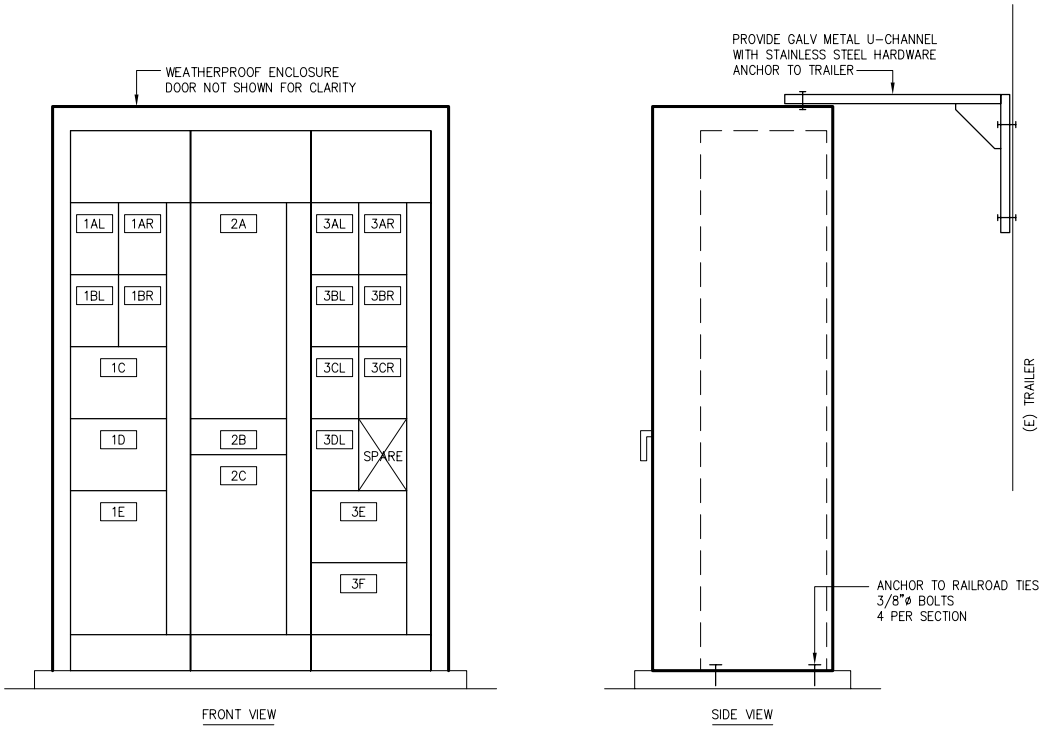

**MOTOR CONTROL CENTER ELEVATION**  
 SCALE: 3/4" = 1'-0"

PANELBOARD "A" SCHEDULE								
CKT No.	DESCRIPTION	100 AMP BUS		AMPS/POLES	CKT No.	DESCRIPTION	80 AMP MAIN	
		VOLT-AMPS A	B				VOLT-AMPS A	B
1	SECURITY/FLOOD/MOTION DETECTOR	100		20/1	2	SPENT WW PUMP 1/3 HP	864	20/1
3	RELAY CONTROL POWER		180	20/1	4	SUMP PUMP 1/3 HP	864	20/1
5	EXTERIOR RECEPTACLE (5)	900		20/1	6	MIXER	696	20/1
7	EXTERIOR RECEPTACLE (5)		900	20/1	8	CHEMICAL FEED RCPT 1		720
9	SPARE			20/1	10	CHEMICAL FEED RCPT 2	720	20/1
11	AIR COMPRESSOR - USF		500	20/1	12	CHEMICAL FEED RCPT 3	720	20/1
13	AIR COMPRESSOR - ZENON	500		20/1	14	CHEMICAL FEED RCPT 4	720	20/1
15	SPACE				16	TURBIDITY INSTRUMENT #1		30
17	SPACE				18	TURBIDITY INSTRUMENT #2		30
19	SPACE				20	SPARE		
21	SPACE				22	SPARE		
23	SPACE				24	SPARE		
25	SPACE				26	CLARIFIER PUMP WITH ST 1/3 HP	864	20
27	TRAILER		1000	30/2	28	CLARIFIER PUMP WITH ST		
29	TRAILER	1000			30			
SUBTOTALS		2500	2580				3030	3198
PHASE TOTALS							5530	5778
TOTAL VOLT-AMPS								11,308

ST = SHUNT TRIP BREAKER (120V)

**SUBMITTAL FOR APPROVAL**

N:\2004\0468029.00 MMWD Seawater Desalination\E1.dwg  
 PRINT DATE: Feb. 03, 2005 - 4:52pm

<b>USE OF DOCUMENTS</b> THIS DOCUMENT, INCLUDING THE INCORPORATED DESIGNS, IS AN INSTRUMENT OF SERVICE FOR THIS PROJECT AND SHALL NOT BE USED FOR ANY OTHER PROJECT WITHOUT THE WRITTEN AUTHORIZATION OF KENNEDY/JENKS CONSULTANTS.	<b>Todd K. Reynolds C59630</b>		DESIGNED TEK	 <b>Kennedy/Jenks Consultants</b> Engineers & Scientists in association with  <b>CH2M HILL</b>	<b>MARIN MUNICIPAL WATER DISTRICT</b> <b>SEAWATER DESALINATION PILOT PLANT PROGRAM</b>  Kennedy/Jenks Consultants 622 FOLSOM STREET, SAN FRANCISCO, CA 94107	<b>ELECTRICAL SINGLE LINE DIAGRAM AND PANELBOARD SCHEDULE</b>	FILE NAME
			DRAWN WL/JL				JOB NO. 0468029.00
			CHECKED TIW				DATE 1 Feb. 2005
	NO.	REVISION	DATE				BY